

SECTION B-B  
SCALE 2 : 3

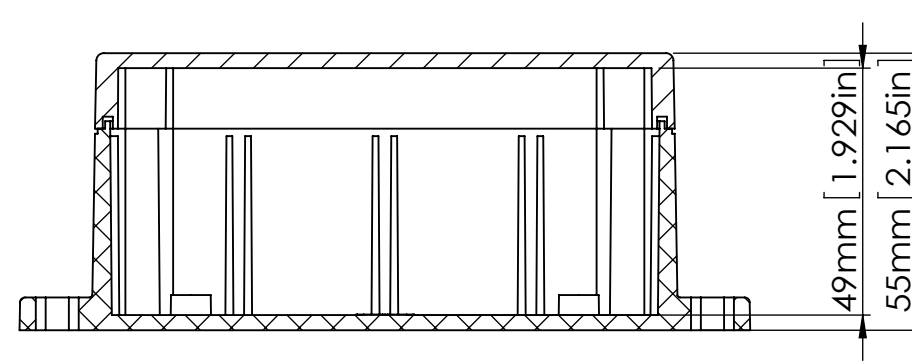
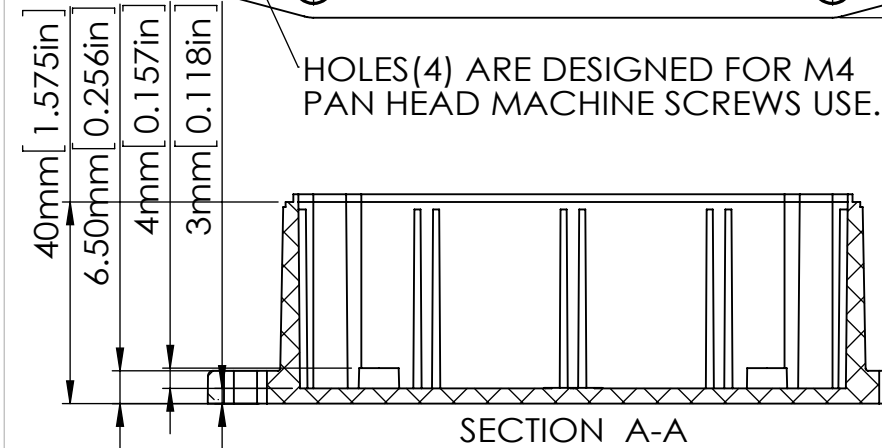
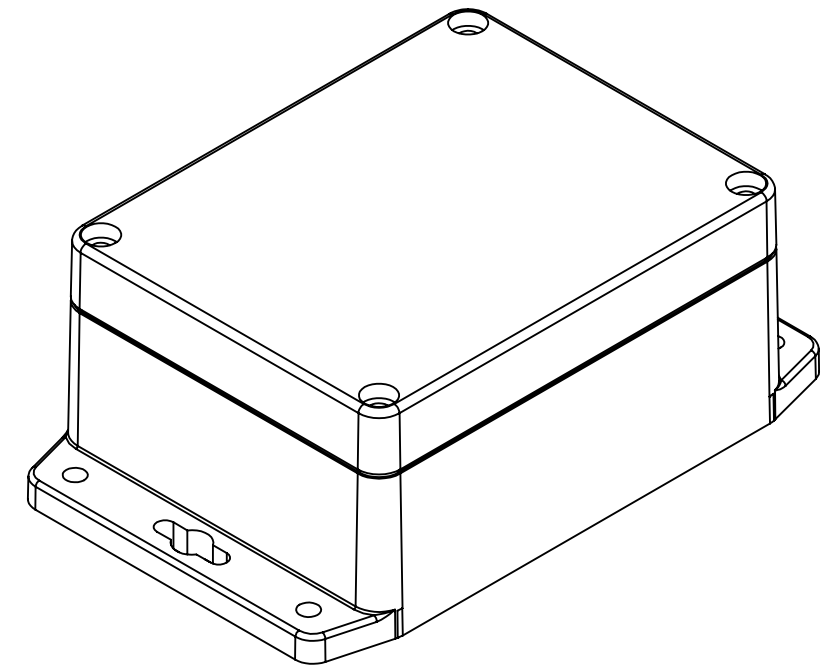
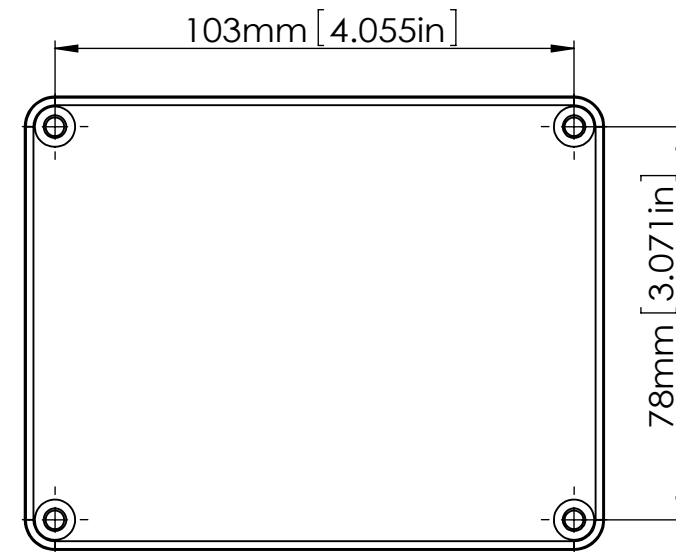
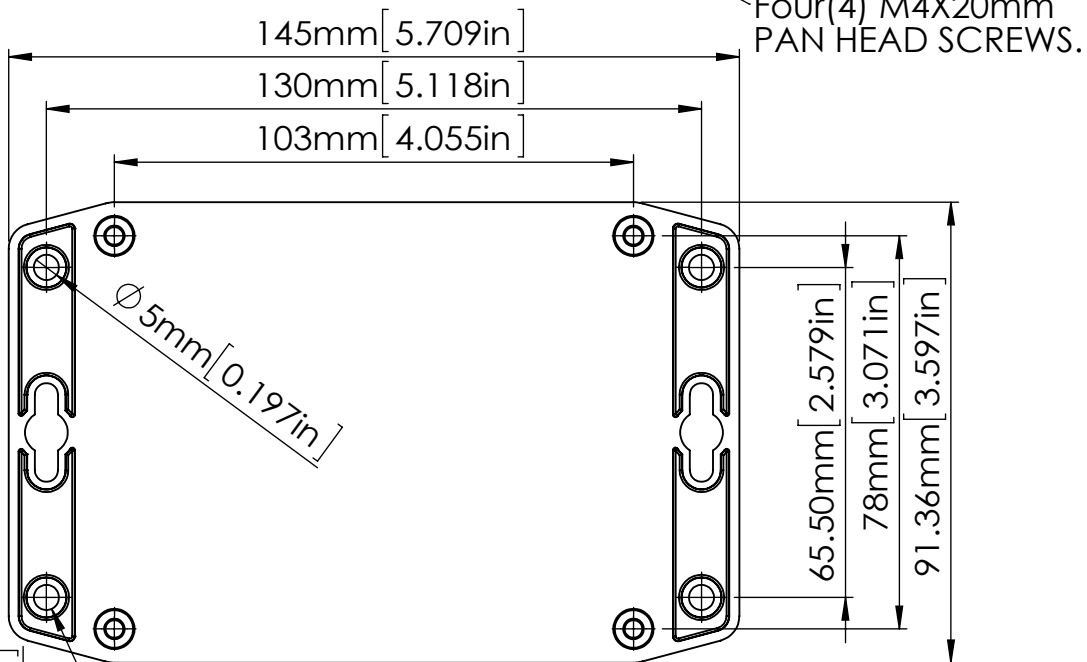

According to ISO 2768-m

Measuring DIM=L	Tolerances
0.5<L<=3.0mm	±0.1mm
3.0<L<=6.0 mm	±0.1mm
6.0<L<=30.0 mm	±0.2mm
30.0<L<=120.0 mm	±0.3mm
120.0<L<=400.0 mm	±0.5mm
400.0<L<=1000.0 mm	±0.8mm

STOCK NO.	MATERIAL	BASE-COLOR	COVER-COLOR
G212MF	POLYCARBONATE UL94-HB	LIGHT GRAY(RAL7035)	LIGHT GRAY(RAL7035)
G212CMF	POLYCARBONATE UL94-HB	LIGHT GRAY(RAL7035)	CLEAR
G311MF	ABS UL94-HB	DARK GRAY(RAL7000)	DARK GRAY(RAL7000)

宣又實業有限公司  
GAINTA INDUSTRIES LTD.

繪圖 DRA'D BY  
JACKY

日期 DATE  
2019/06/18

材質 MATE.  
PC;ABS

圖名TITLE:  
G212MF ; G311MF

圖號DWG NO:

版次REVISID:

B