

M3X4mm SELF-TAPPING SCREWS (NOT SUPPLIED).

FOUR(4) M4X20mm PAN HEAD SCREWS.

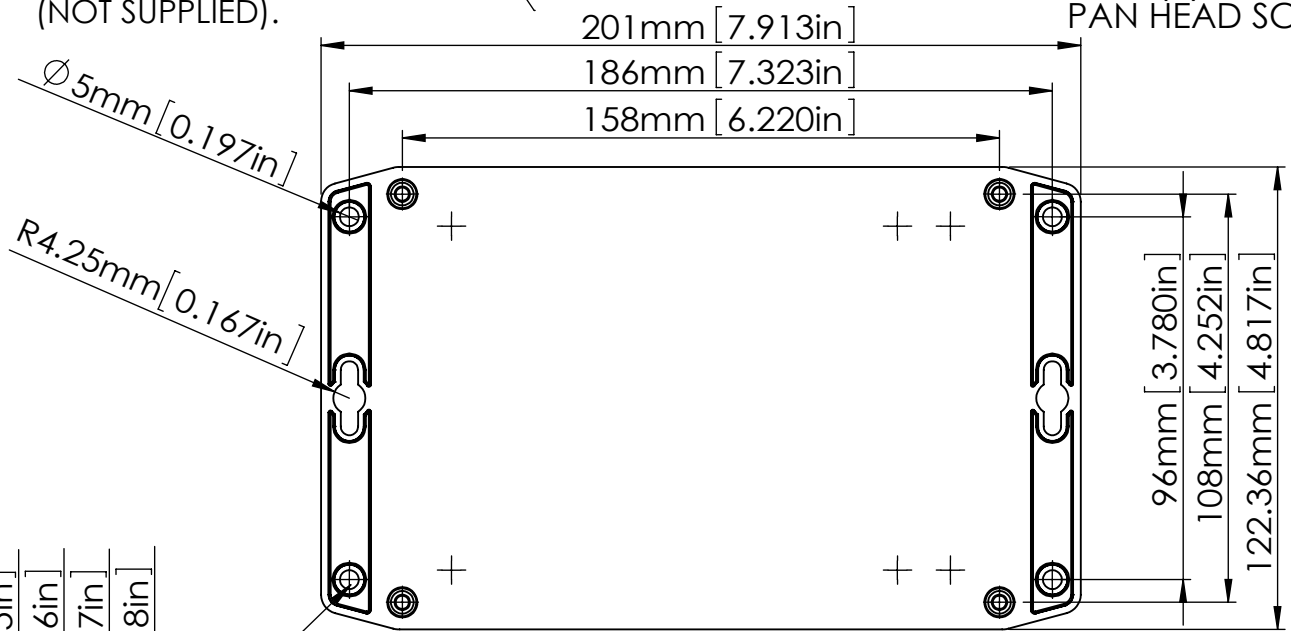

HOLES(4) ARE DESIGNED FOR M4 PAN HEAD SCREWS(NOT SUPPLIED).

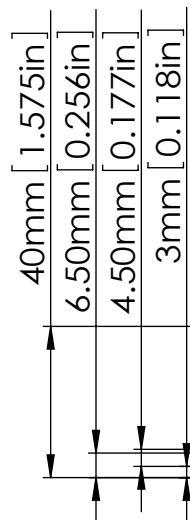

SECTION A-A

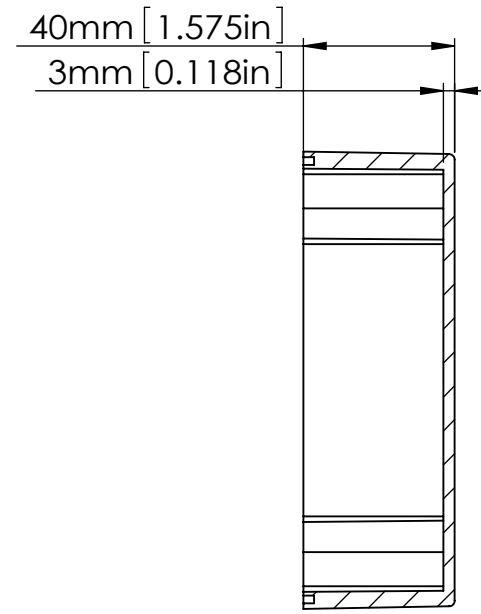
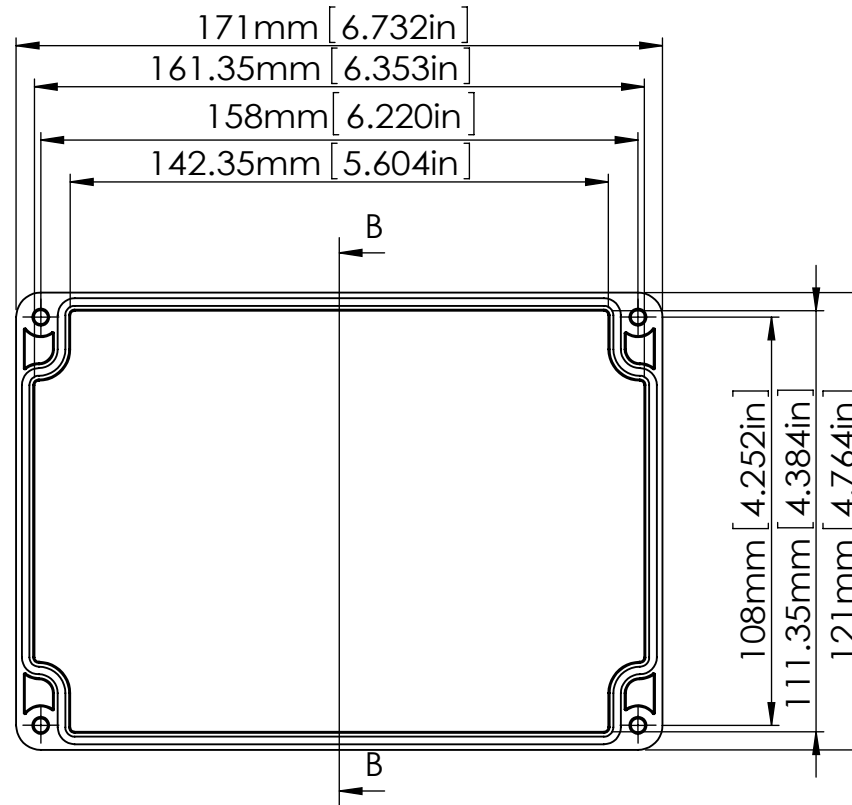

SECTION B-B

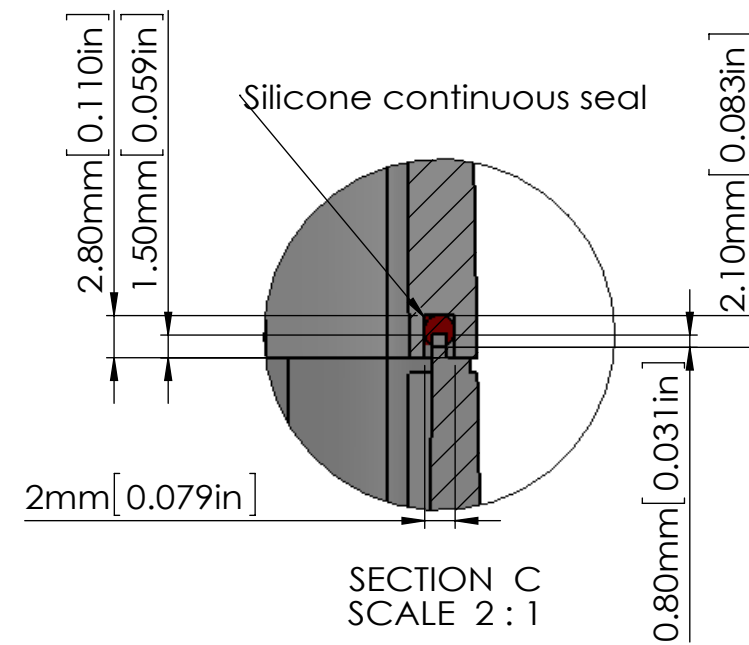

SECTION C SCALE 2:1

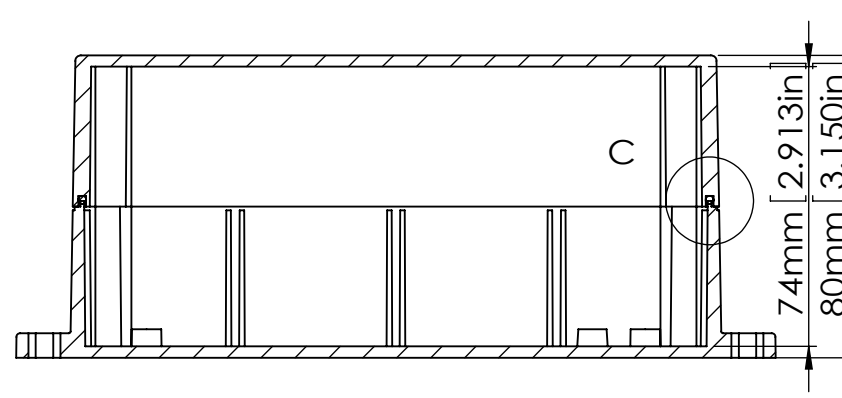

According to ISO 2768-m	
Measuring DIM=L	Tolerances
0.5<L<=3.0mm	±0.1mm
3.0<L<=6.0 mm	±0.1mm
6.0<L<=30.0 mm	±0.2mm
30.0<L<=120.0 mm	±0.3mm
120.0<L<=400.0 mm	±0.5mm
400.0<L<=1000.0 mm	±0.8mm

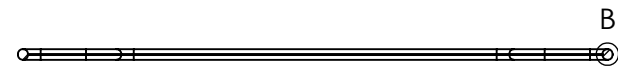
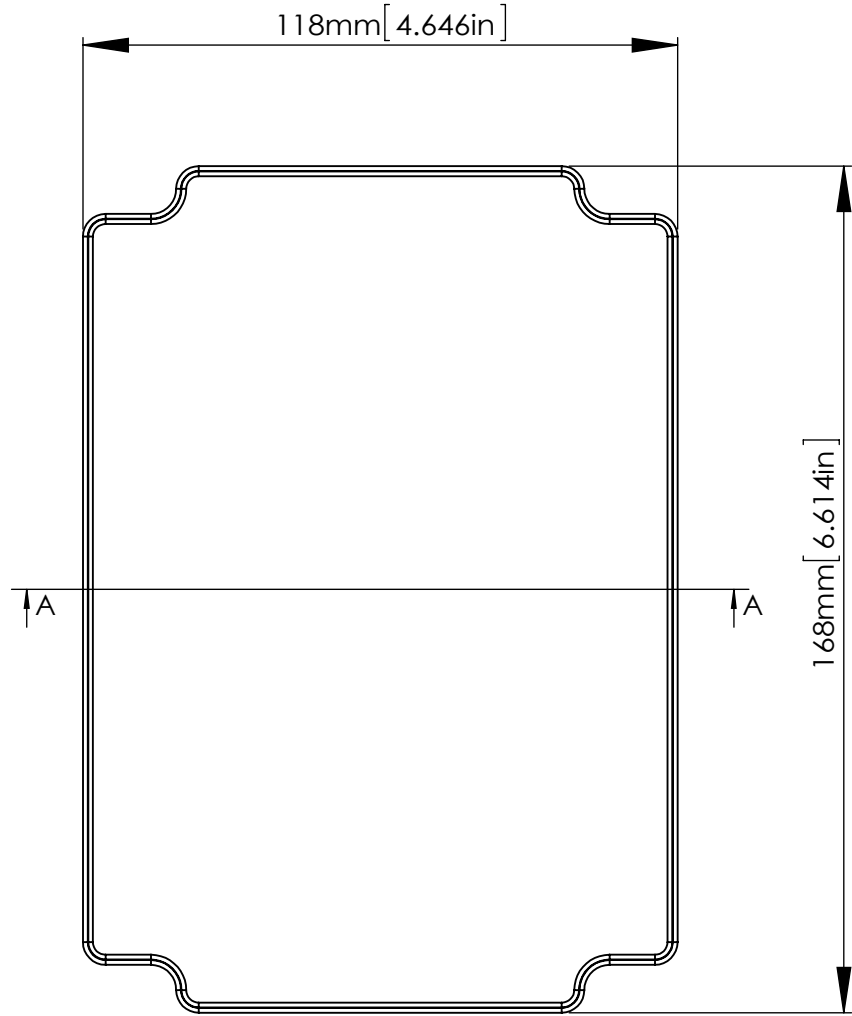

SECTION A-A
SCALE 2 : 3

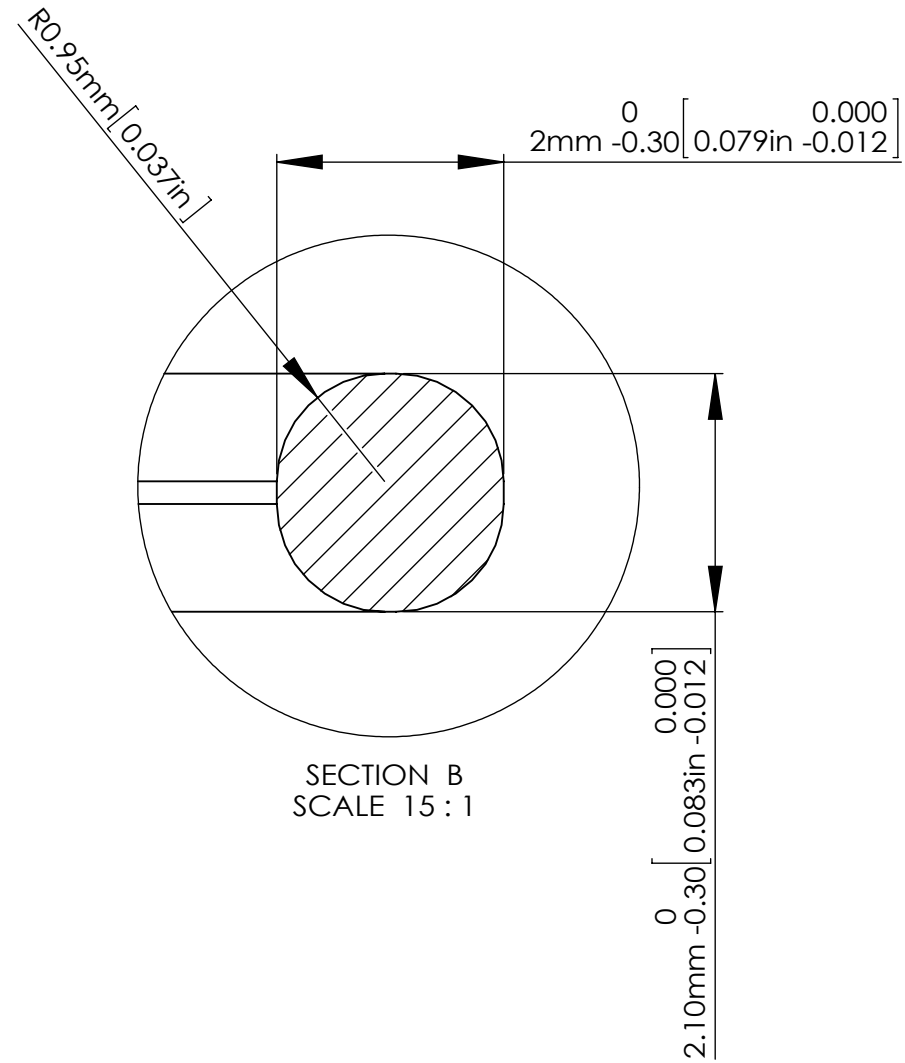

SECTION B
SCALE 15 : 1

According to ISO 2768-m	
Measuring DIM=L	Tolerances
0.5<L<=3.0mm	±0.1mm
3.0<L<=6.0 mm	±0.1mm
6.0<L<=30.0 mm	±0.2mm
30.0<L<=120.0 mm	±0.3mm
120.0<L<=400.0 mm	±0.5mm
400.0<L<=1000.0 mm	±0.8mm

宣又實業有限公司
GAINTA INDUSTRIES LTD.

繪圖 DRA'D BY
JACKY

日期 DATE
2020/02/20

材質 MATE.
SILICONE

圖名TITLE:
P214SEAL/A313SEAL;
P223SEAL/A340SEAL

圖號DWG NO:

版次REVISED:
A