

## NEW DESIGN SEALED POLYCARBONATE AND ABS PLASTIC ENCLOSURES

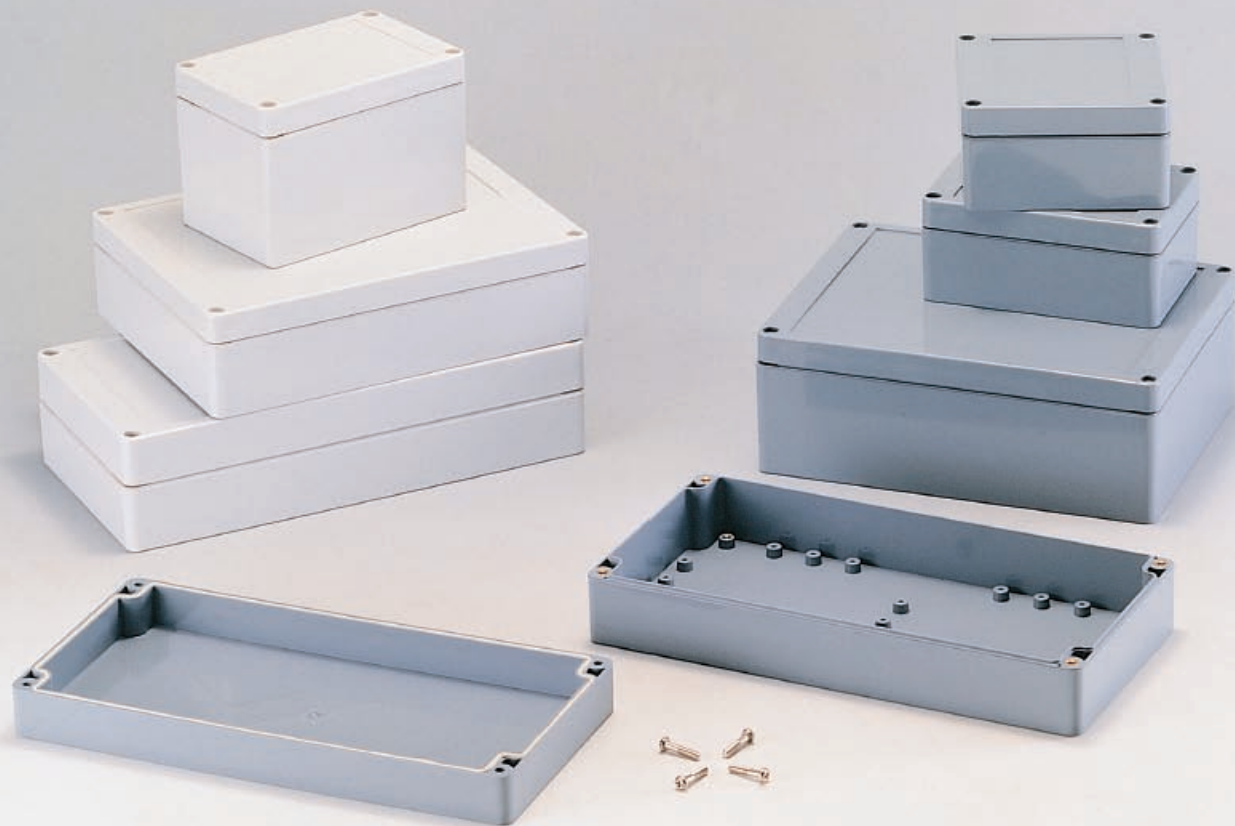

### PRODUCT INFORMATION

#### MATERIAL :

- Polycarbonate in light grey cover and body.
- Polycarbonate in clear cover and light grey body.
- ABS in dark grey cover and body.

#### FEATURES:

- Designed to IP65 specification.
- Wall mounting holes and cover attaching screws are outside the sealing area thus preventing ingress of moisture and dust.
- Internal bosses allow mounting of PCB horizontally or for connection of terminals, Etc..... Into threaded inserts.
- Cover screws are M4 stainless steel, non-magnetic and fasten into thread brass inserts.
- Recessed area on cover for sticking membrane keyboard.



G2119



G2119C

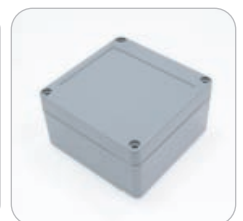

G3101



G2119

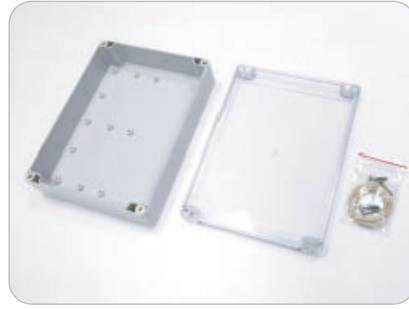

G2119C

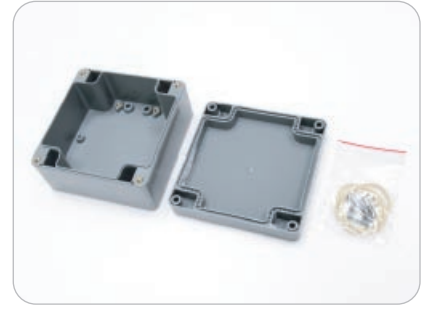

G3101

MATERIAL: POLYCARBONATE					
ITEM No.	COLOR		ITEM No.	COLOR	
	LID	BASE		LID	BASE
G2100	Light Grey		G2100C	Clear	Light Grey
G2102	Light Grey		G2102C	Clear	Light Grey
G2104	Light Grey		G2104C	Clear	Light Grey
G2105	Light Grey		G2105C	Clear	Light Grey
G2111	Light Grey		G2111C	Clear	Light Grey
G2113	Light Grey		G2113C	Clear	Light Grey
G2117	Light Grey		G2117C	Clear	Light Grey
G2119	Light Grey		G2119C	Clear	Light Grey
G2120	Light Grey		G2120C	Clear	Light Grey
G2128	Light Grey		G2128C	Clear	Light Grey
G2135	Light Grey		G2135C	Clear	Light Grey

MATERIAL: ABS			
ITEM No.	COLOR		EXTERNAL DIMENSION(mm)
	LID	BASE	
G3101	Dark Grey		100 x 100 x 55
G3103	Dark Grey		100 x 100 x 90
G3107	Dark Grey		120 x 80 x 55
G3109	Dark Grey		120 x 80 x 85
G3113	Dark Grey		200 x 120 x 90
G3118	Dark Grey		240 x 120 x 60
G3121	Dark Grey		240 x 120 x 100
G3122	Dark Grey		200 x 150 x 55
G3127	Dark Grey		200 x 150 x 75
G3130	Dark Grey		353 x 140 x 121.5
G3125	Dark Grey		190 x 190 x 55

G2135 / G3125

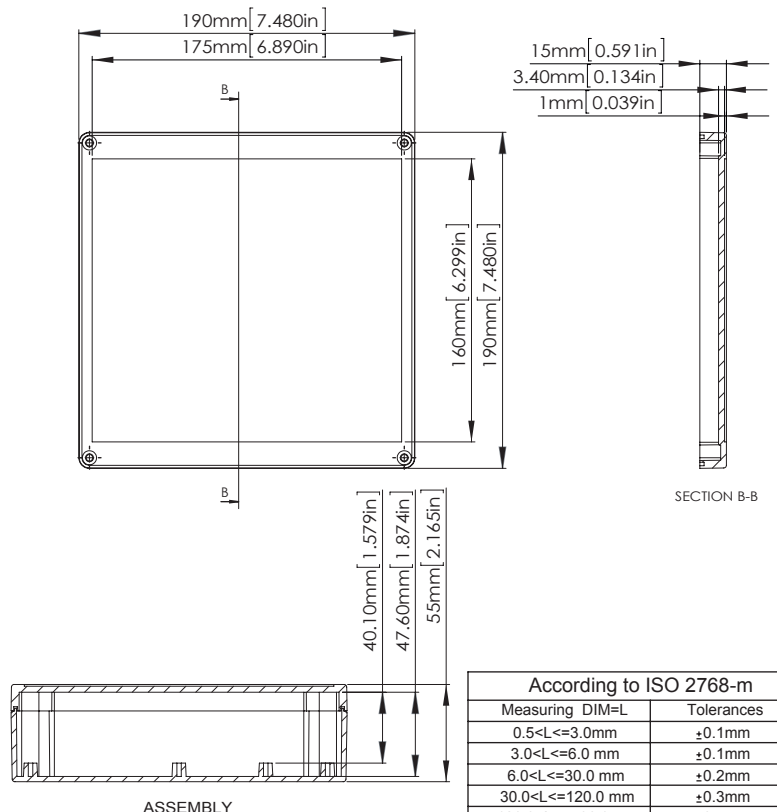
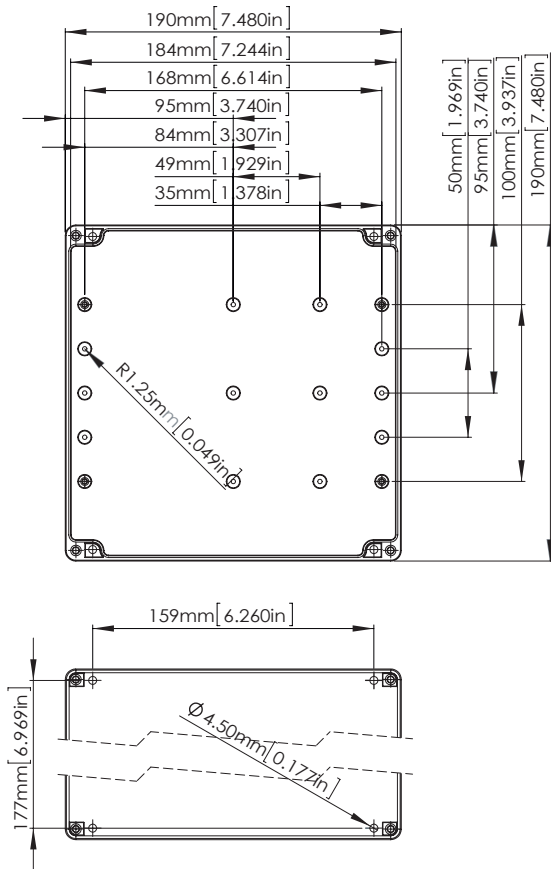

**G2100 / G3101**

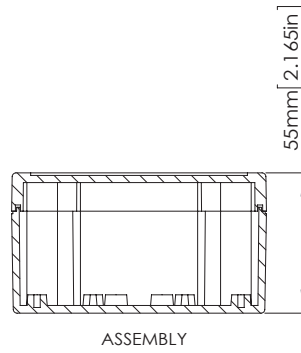
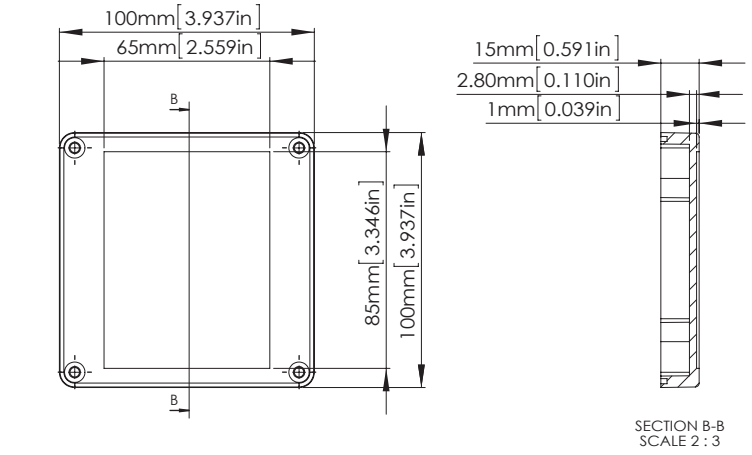
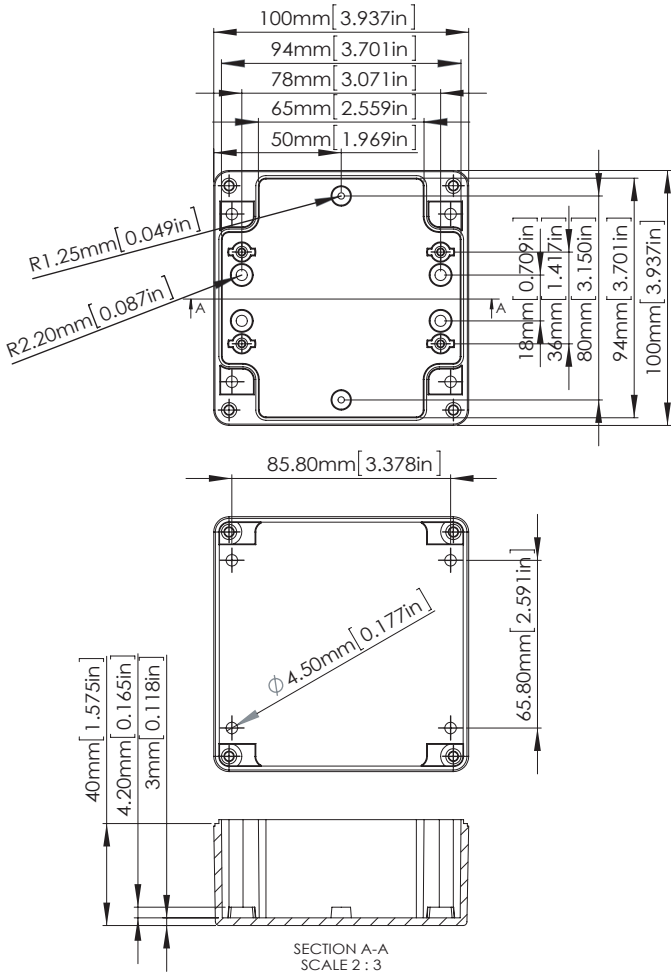

According to ISO 2768-m	
Measuring DIM=L	Tolerances
0.5<L<=3.0mm	±0.1mm
3.0<L<=6.0 mm	±0.1mm
6.0<L<=30.0 mm	±0.2mm
30.0<L<=120.0 mm	±0.3mm
120.0<L<=400.0 mm	±0.5mm
400.0<L<=1000.0 mm	±0.8mm

**G2102 / G3103**

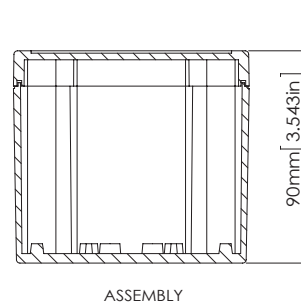
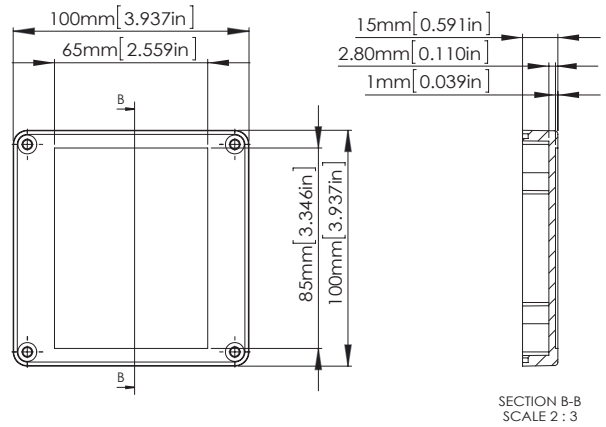
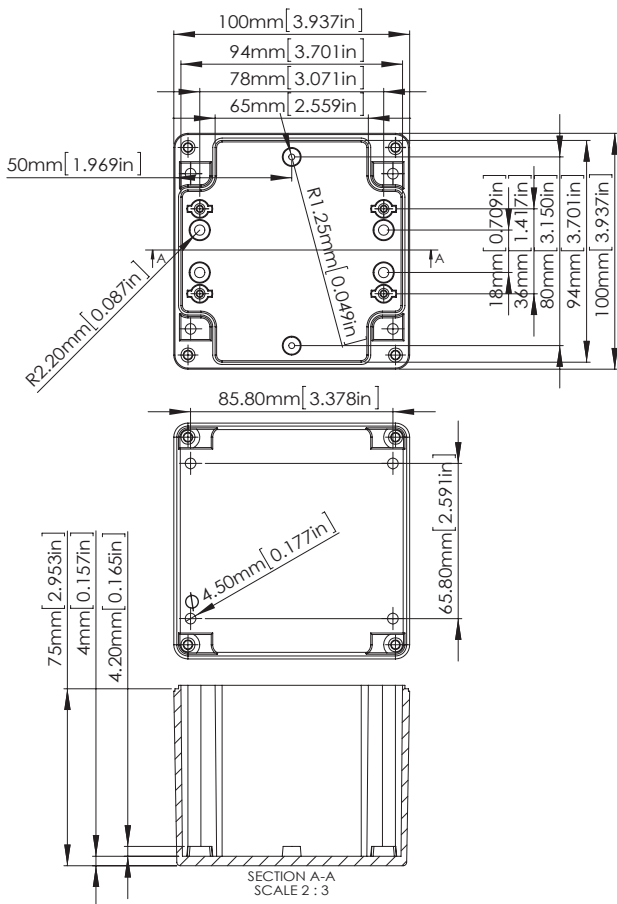

According to ISO 2768-m	
Measuring DIM=L	Tolerances
0.5<L<=3.0mm	±0.1mm
3.0<L<=6.0 mm	±0.1mm
6.0<L<=30.0 mm	±0.2mm
30.0<L<=120.0 mm	±0.3mm
120.0<L<=400.0 mm	±0.5mm
400.0<L<=1000.0 mm	±0.8mm

## G2104 / G3107

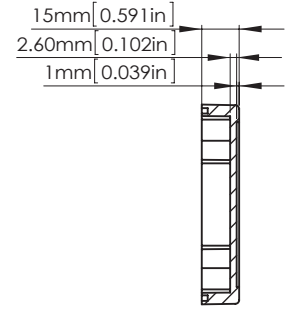
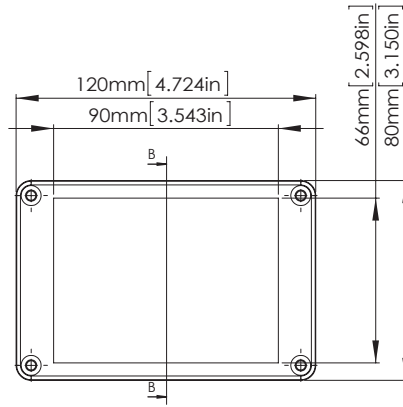
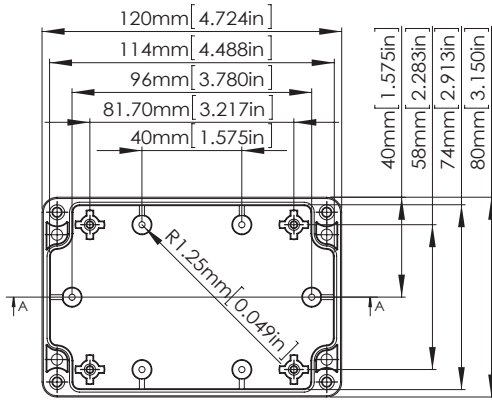

SECTION B-B  
SCALE 2 : 3

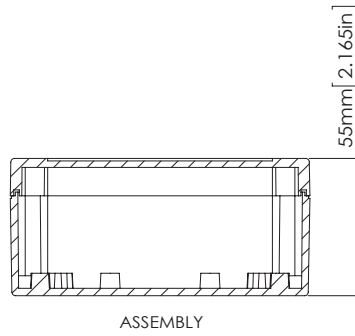
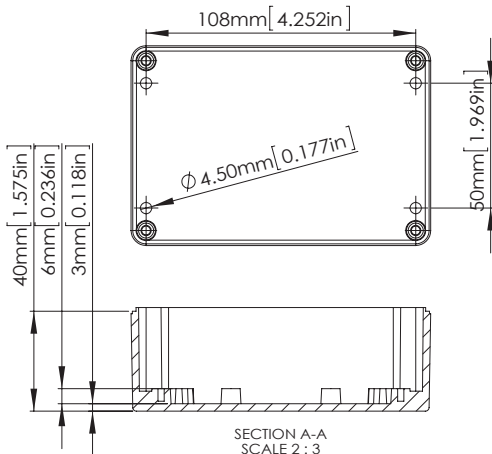

ASSEMBLY

According to ISO 2768-m	
Measuring DIM=L	Tolerances
0.5<L<=3.0mm	±0.1mm
3.0<L<=6.0 mm	±0.1mm
6.0<L<=30.0 mm	±0.2mm
30.0<L<=120.0 mm	±0.3mm
120.0<L<=400.0 mm	±0.5mm
400.0<L<=1000.0 mm	±0.8mm

SECTION A-A  
SCALE 2 : 3

## G2105 / G3109

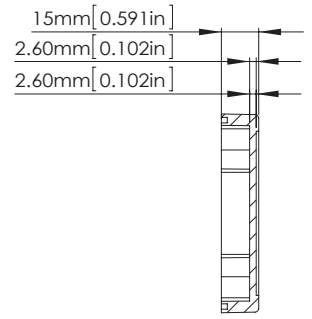
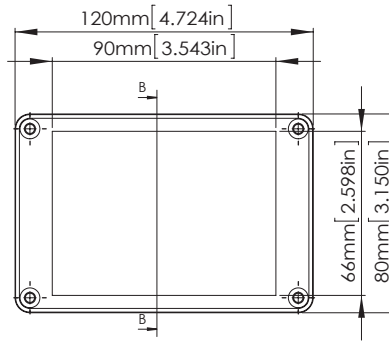
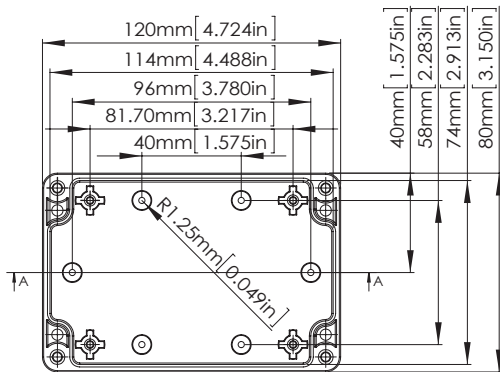

SECTION B-B  
SCALE 2 : 3

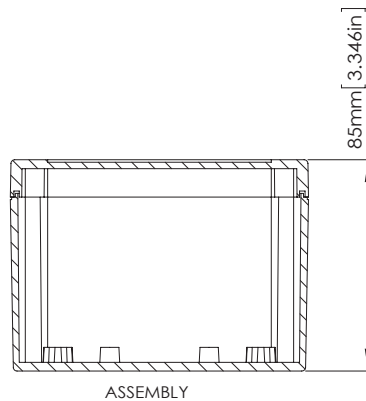
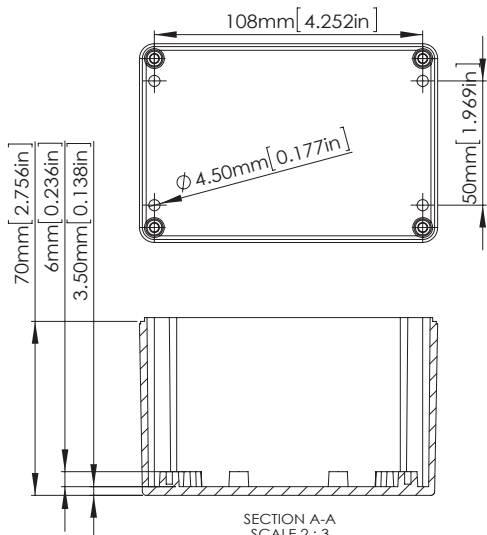

ASSEMBLY

According to ISO 2768-m	
Measuring DIM=L	Tolerances
0.5<L<=3.0mm	±0.1mm
3.0<L<=6.0 mm	±0.1mm
6.0<L<=30.0 mm	±0.2mm
30.0<L<=120.0 mm	±0.3mm
120.0<L<=400.0 mm	±0.5mm
400.0<L<=1000.0 mm	±0.8mm

SECTION A-A  
SCALE 2 : 3

## G2111 / G3113

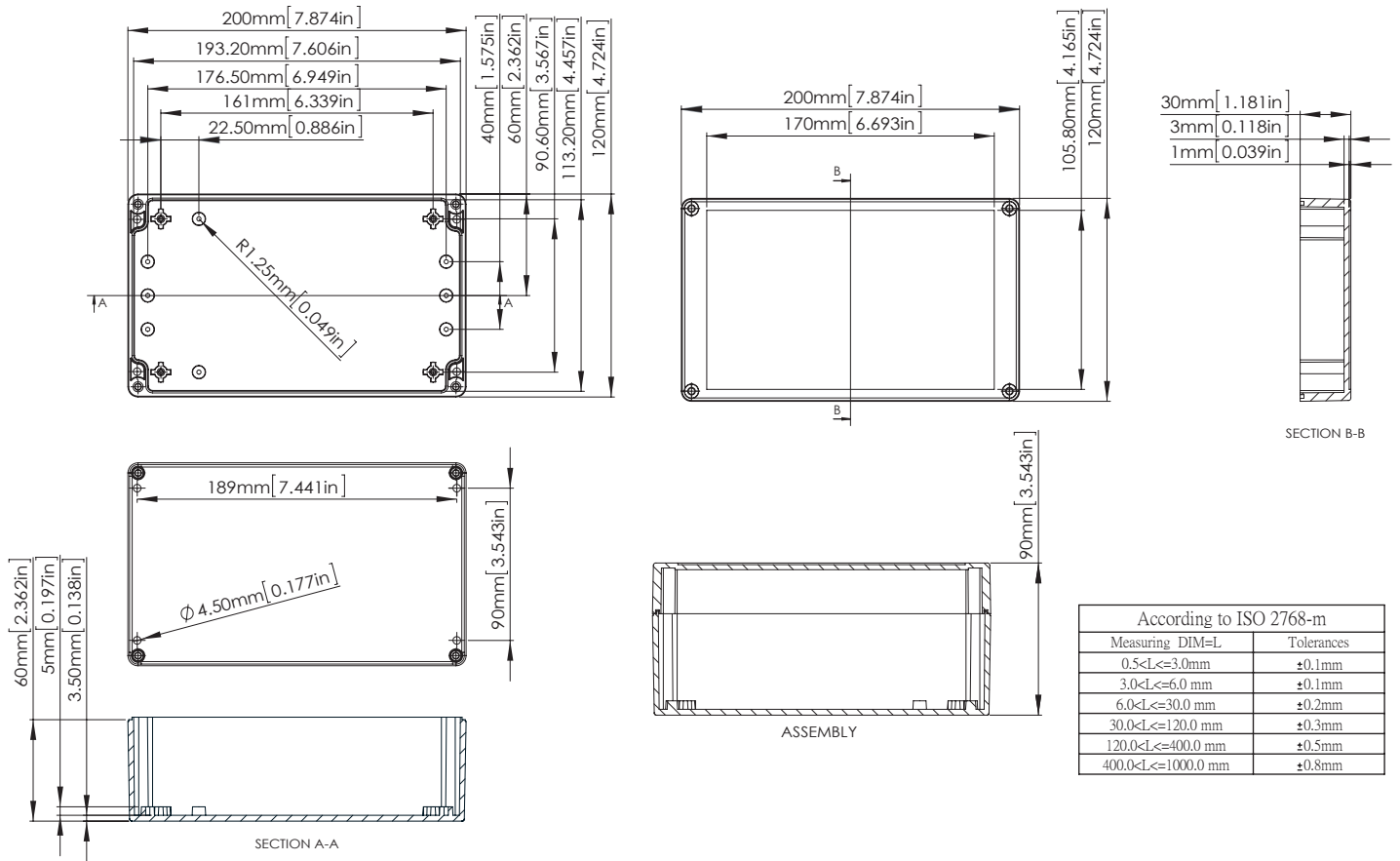

## G2113 / G3118

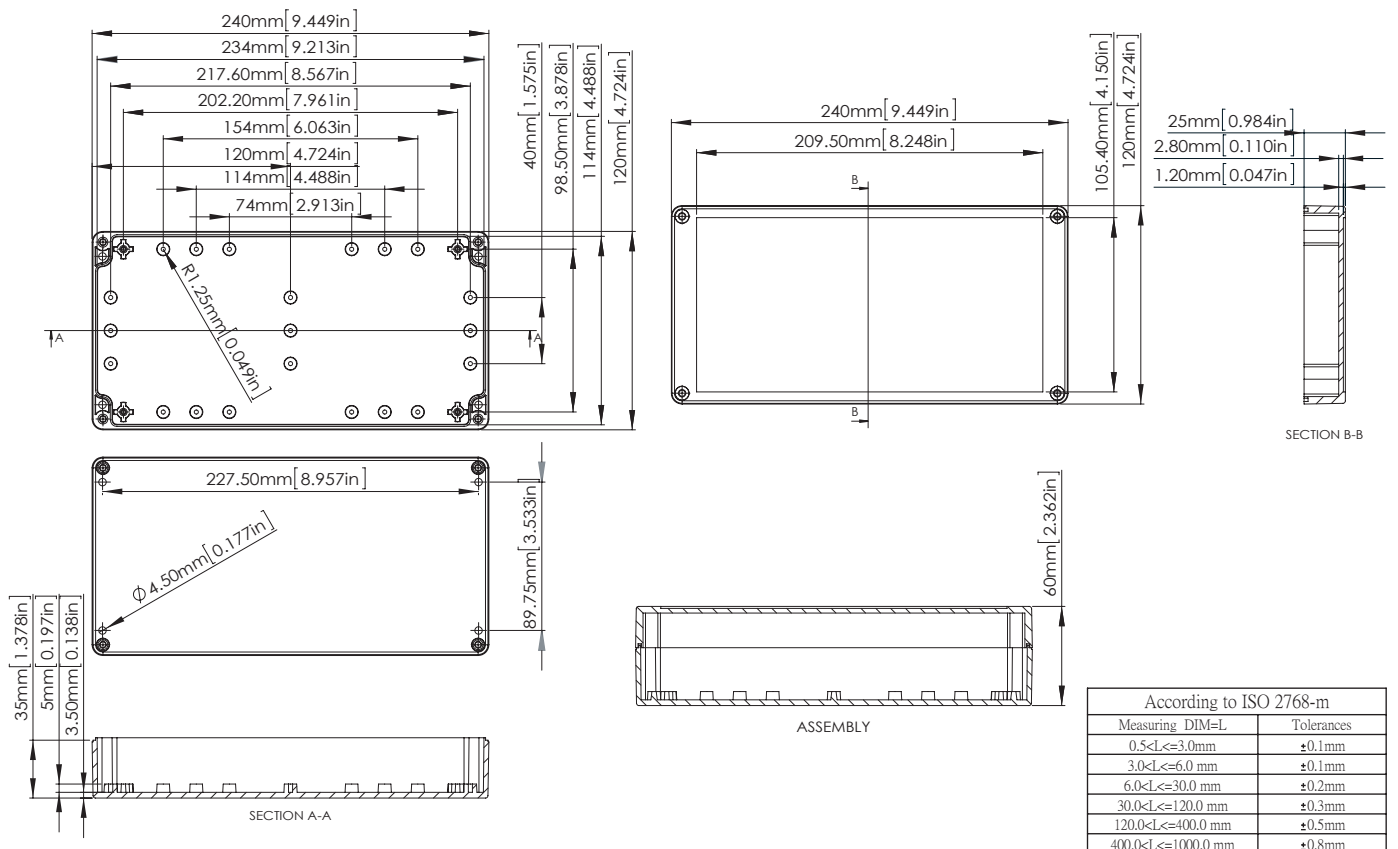

## G2117 / G3121

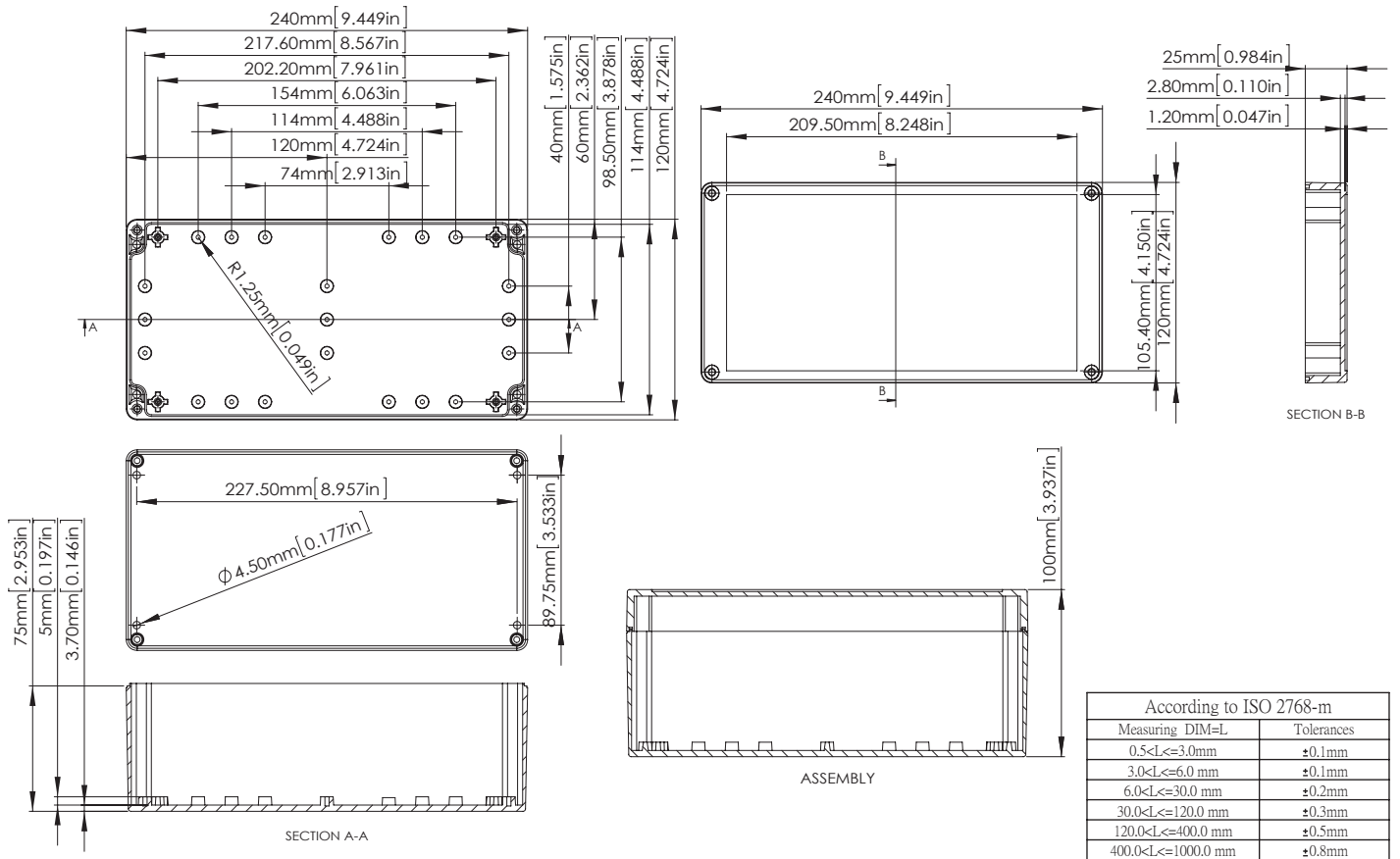

## G2119 / G3122

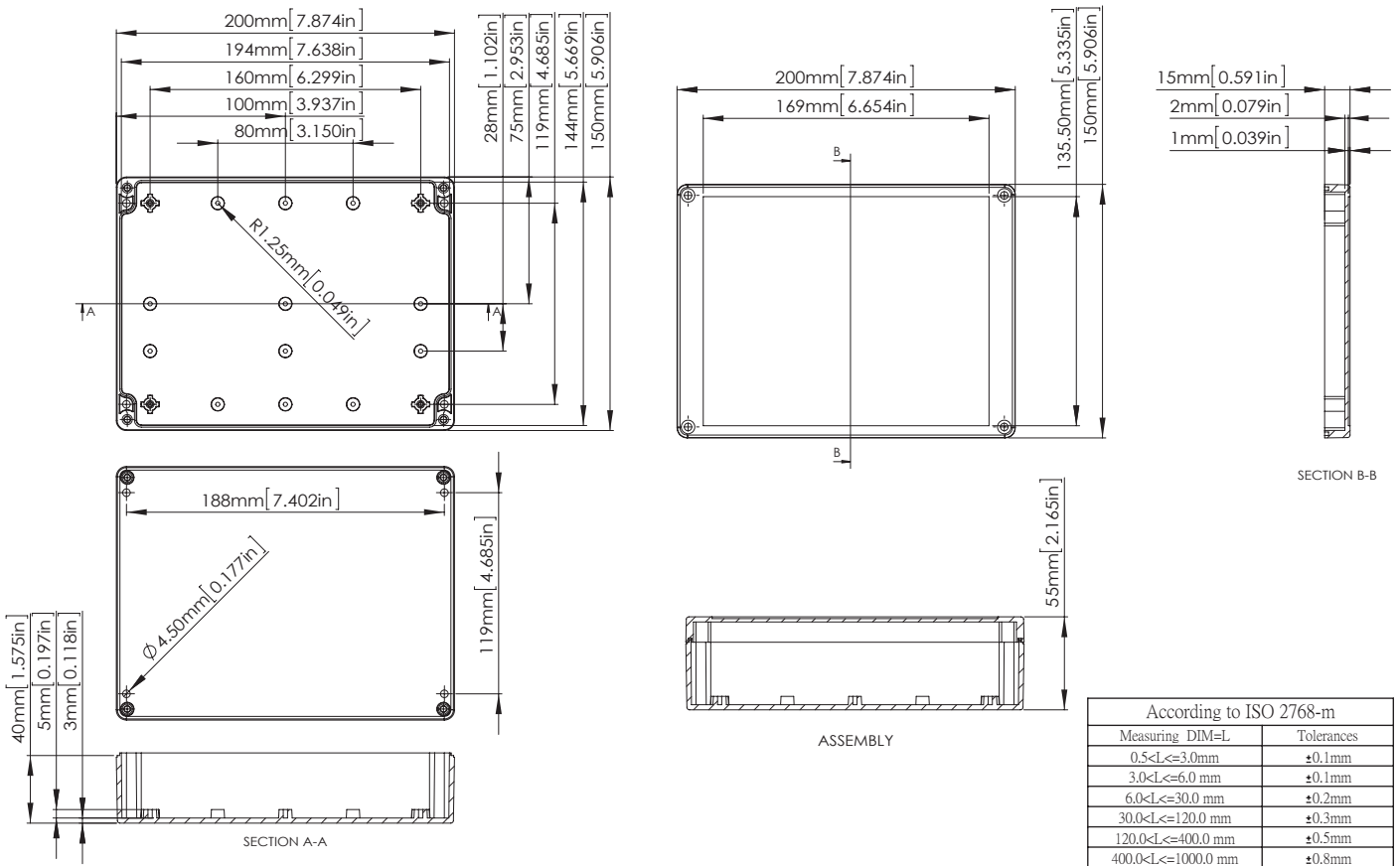

## G2120 / G3127

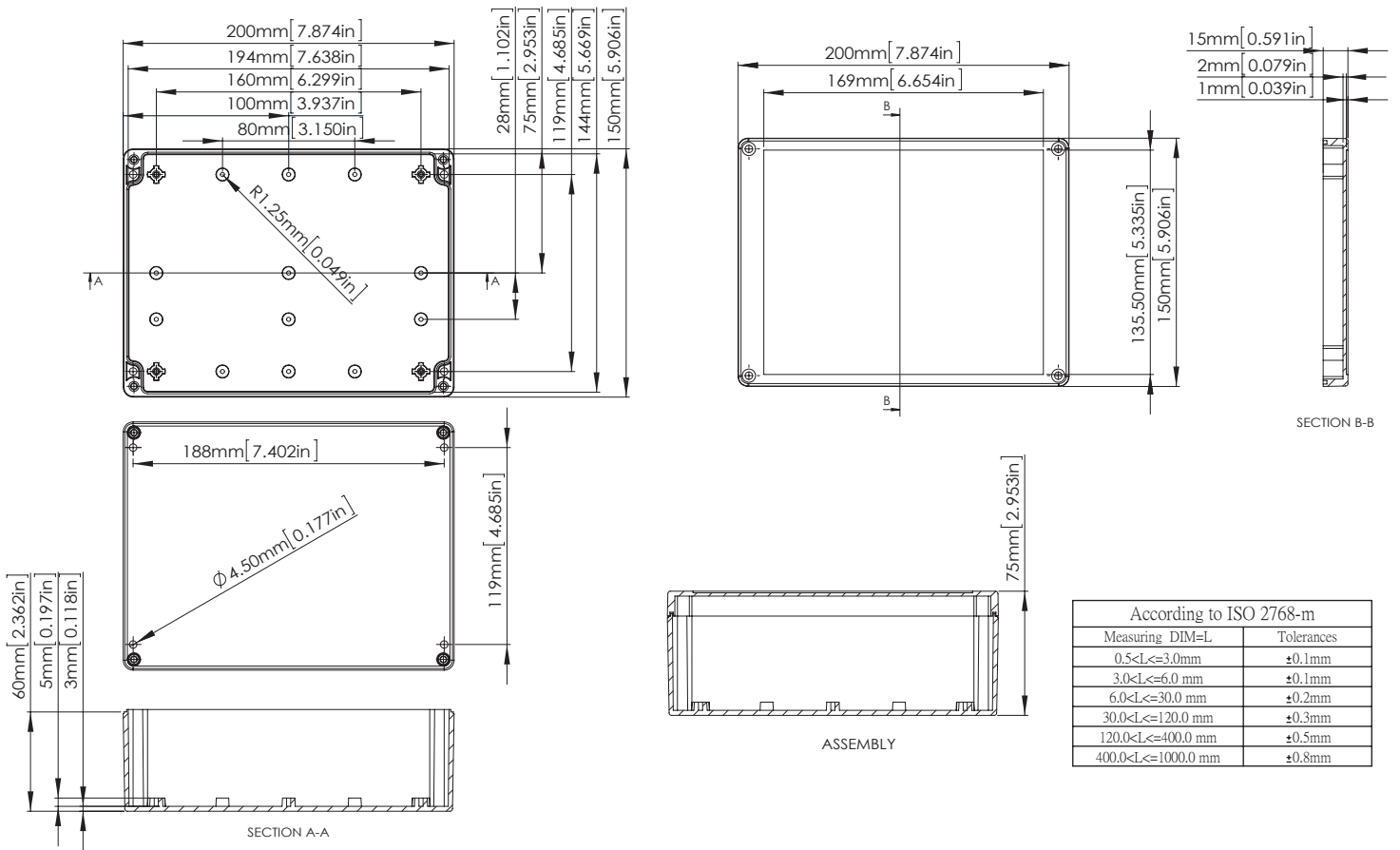

## G2128 / G3130

